

ZEBRA Batteries are designed for electric and hybrid vehicles.
They use salt and nickel for electrode materials with a ceramic electrolyte.

Technical data **ZEBRA® Battery**
Type Z5

	Z5-278-ML3X-64 <i>Id. No. 30x00006</i>	Z5-557-ML3X-32 <i>30x00007</i>	Z5-278-ML3X-76 <i>30x00129</i>	Z5-557-ML3X-38 <i>30x00131</i>
	<i>unit</i>			
Capacity	Ah 64	32	76	38
Rated Energy	kWh 17.8	17.8	21.2	21.2
Open circuit voltage				
0 - 15% DOD	V 278	557	278	557
Max. regen. voltage	V 313	626	335	670
Min. op. voltage	V 186	372	186	372
Max. discharge current	A 224	112	224	112
Cell Type / N° of cells	ML3X / 216		ML3X/216	
Weight with BMI	kg 182		182	
Specific energy without BMI	Wh/kg 100		119	
Energy density without BMI	Wh/l 152		181	
Energy 2 h discharge	kWh 16		18.0	
Specific power	W/kg 179		169	
Power density	W/l 273		257	
Peak power	kW 30		30	
2/3 OCV, 30s, 335°C	80% DOD		70% DOD	
Ambient temperature	°C -40 to +50		-40 to +50	
Thermal loss	W < 105		< 105	
at 270°C internal temperature				
Cooling	air		air	
Heating time	h 24 h at 230 VAC		24 h at 230 VAC	
Periphery	BMI, Fan HEV Application		BMI, Fan EV Application	
On board generator				
MAX voltage, up to 70%SOC	V/Cell 2.7		n.a.	

System design recommendation:

- MES-DEA Charger
- Min. discharging time: 120 min.
- Max. degree of discharge: 80%

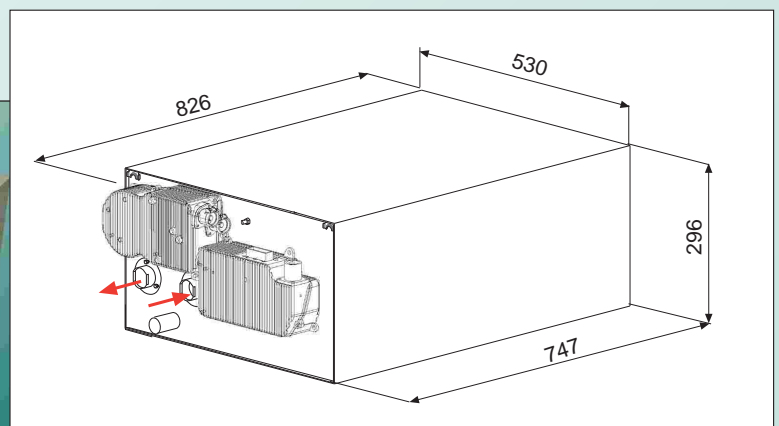

The information contained herewith is subject to change without notice

